



EN16005 CA FIELD TEST BOX

TEST DEVICES

RGL now offer a wide range of EN16005 test devices, including CA-TEST-BOX, CB-TEST-BODY, & ESPE Hinge Tester.



CA-TEST-BOX

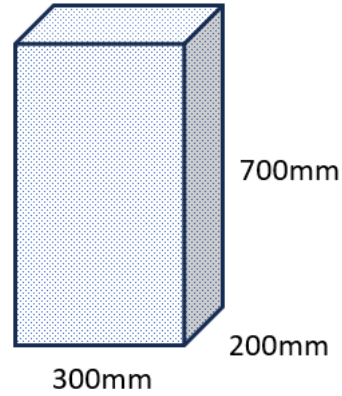

SPECIFICATION

CA-TEST-BOX

- The top and two sides are made of a low reflectance material, the other 2 sides are made of a higher reflective material.
- BS EN 16005 compliant

- Check during automatic door installation & maintenance that sensor safety zones are set up to maximize pedestrian safety

FEATURES

CA-TEST-BOX

- Grey (RAL 7040 matt)
- Black (RAL 9004 matt)
- Extremely durable - designed to be flat packed for easy storage in your vehicle, yet robust enough for long term site usage.
- Designed in line with the Automatic Door Suppliers Association specification.

OTHER PRODUCTS

CBTESTBODY



EXT/AP/KS-1



ESPE HT-1



AS900



DIMENSIONS

CA-TEST-BOX

- 700 x 300 x 200 (mm) (HxWxD)

CONTENTS

CA-TEST-BOX

- Test Box



Manufactured by a BSIA Member