

# BRACKETS AND ACCESSORIES

\* Available for ML1200 range also

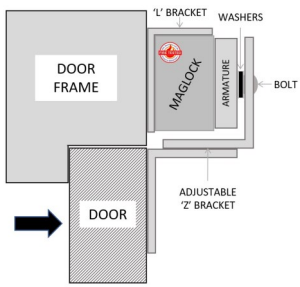

\* BK600ZL  
Inward Opening

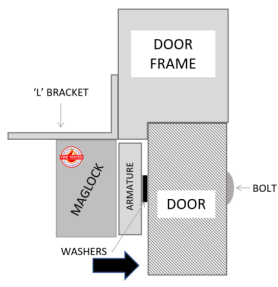

\* BK600L  
Outward Opening

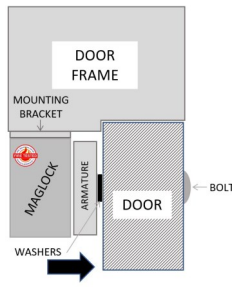

\* BK600U  
Outward Opening

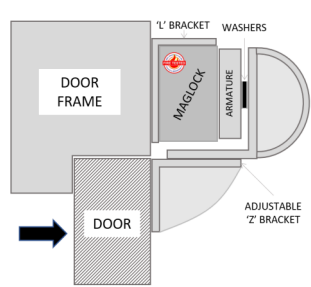
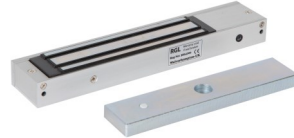

\* AB600ZL-DC or BK600-FL/AB  
Inward Opening



\* AH600  
Armature Housing  
(For use with Fire Doors)

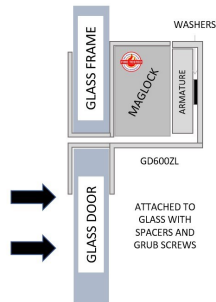

GD600ZL  
Inward Opening  
(glass door and glass frame)



\* Mag-Strap  
Safety Strap for Maglocks  
(For use with Fire Doors)

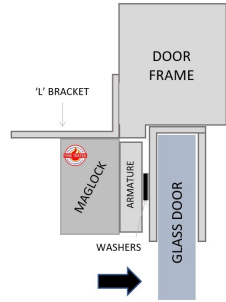

BK600U  
Outward Opening



\* ARMBOLT  
Armature Bolts  
(50mm, 60mm, 80mm, 100mm)



Have you got the correct brackets & Accessories?



# Maglock Range (Instructions)

Models: ML600 / ML1200 (includes Monitored)

	600lbs (280Kg) 12/24VDC Single Door	1200lbs (545Kg) 12/24VDC Single Door	600lbs (280Kg)x2 12/24VDC Double Door	1200lbs (545Kg)x2 12/24VDC Double Door
Unmonitored	ML600	ML1200	ML600-D	
**Monitored	ML600-M	ML1200-M	ML600-D-M	ML1200-D-M
*Max Door Thickness	*45mm	*55mm	*45mm	*55mm

\*This is as supplied with the standard kit, longer bolts are stocked for thicker doors

\*\*Door Status locks are also available

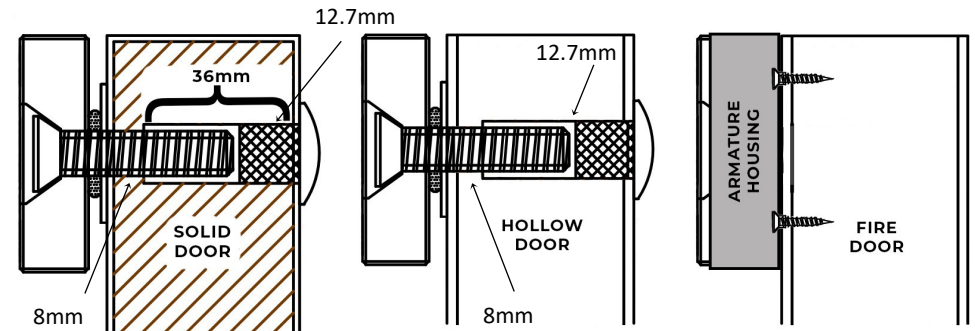
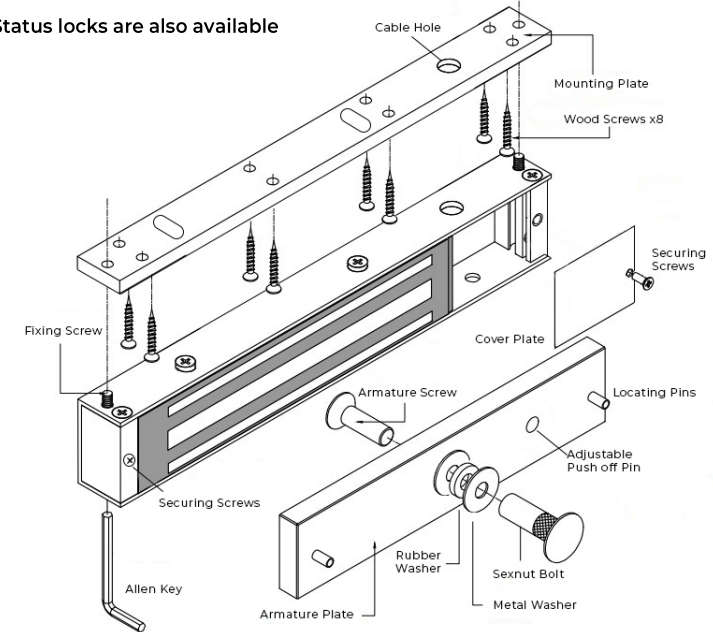

## INWARD OPENING

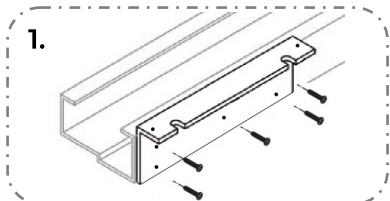

1. Attach 'L' Bracket to door frame

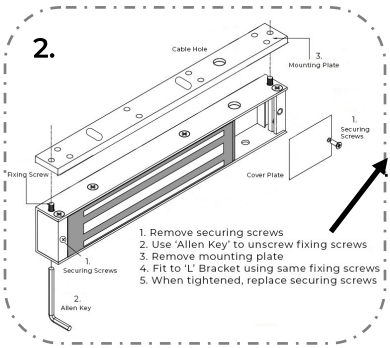

2. Follow instructions to remove mounting plate

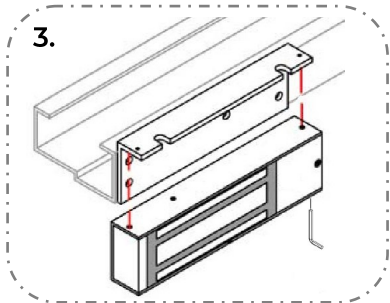

3 & 4 Attach to 'L' Bracket and fit 'Z' as per below

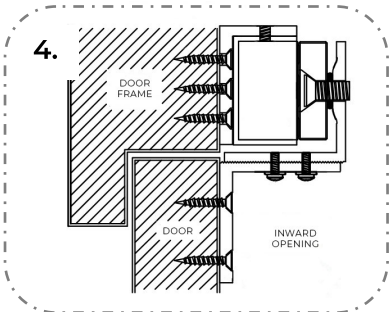

## OUTWARD OPENING

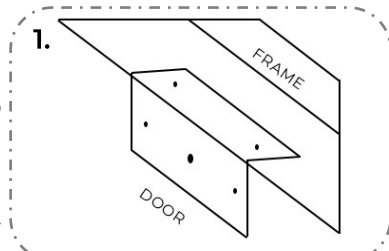

1. Place template on door and drill holes

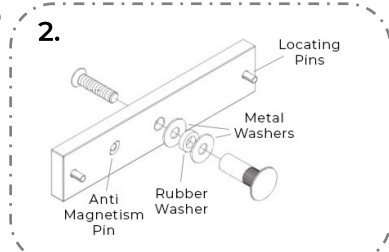

2. Install armature as illustrated above

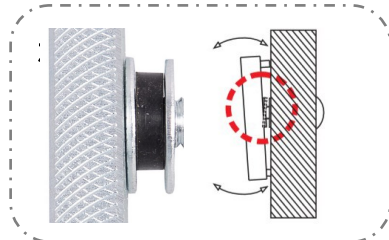

3. You MUST use the rubber washer to allow plenty of movement

4. Follow instructions to remove mounting plate and install to door frame as shown in below image

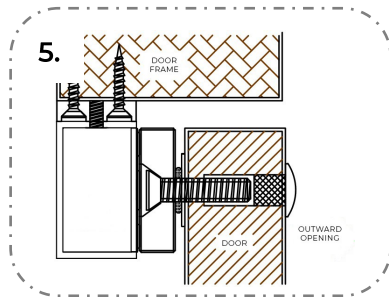

1. Remove securing screws  
2. Use Allen Key to unscrew fixing screws  
3. Remove mounting plate

4. Fit to 'L' Bracket using same fixing screws  
5. When tightened, replace securing screws

## Installation Instructions

**ENSURE YOU SET THE MAGNET TO THE CORRECT VOLTAGE. AS STANDARD IT COMES IN THE 12V POSITION!**

### Non Monitored

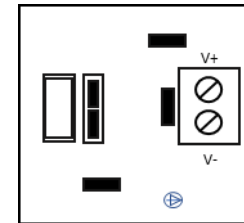

### JUMPER SETTINGS



### Monitored

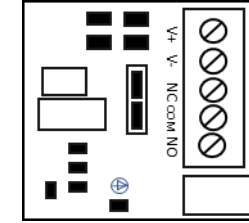

### A: 12VDC Input:

- Required power 0.5Amp (Minimum)
- Connect the positive (+) lead from a 12VDC source to +
- Connect the ground (-) lead from a 12VDC source to -
- Check jumper for 12VDC operation

### B: 24VDC Input:

- Required power 0.25Amp (Minimum)
- Connect the positive (+) lead from a 24VDC source to +
- Connect the ground (-) lead from a 24VDC source to -
- Change jumper for 24VDC operation

### C: Contacts:

- Relay voltage free contacts are rated 1amp at 24VDC for safe operation, do not exceed this rating.
- If you require a normally open switch, connect the wires from the system to C and NO.
- If you require a normally closed switch, connect the wires from the system to C and NC

### IMPORTANT REMINDERS

- Handle the equipment with care, damaging the surface of the magnet or armature plate may reduce locking efficiency
- The magnet is mounted rigidly to the door frame, whereas the armature plate must be mounted to the door using the items provided to allow it to pivot about its centre. This allows it to compensate for door wear and misalignment.
- The template must be used with the door in its normally closed position (Outward opening only)

### TROUBLE SHOOTING

#### 1. Reduced Holding Force

- Poor contact between magnet and armature (check placement)
- Armature if fitted too tightly to door/bracket
- Wrong voltage being used or jumper set to wrong setting
- Check the voltage coming into the lock, if lower than expected check correct cable is being used (we recommend alarm cable - not Cat5/6 or telephone cable)

#### 2. Door not Releasing

- Ensure the degaussing pin on armature is set correctly - use allen key on rear of armature to adjust. Turn clockwise to make pin spring stronger.

#### 3. No Power at Lock

- Check power supply is working correctly
- Check cables are properly secured in the terminals in lock